

SW1: NO micro-switch used on swell pedal.
 SW2: NO momentary Switch (Kbd)

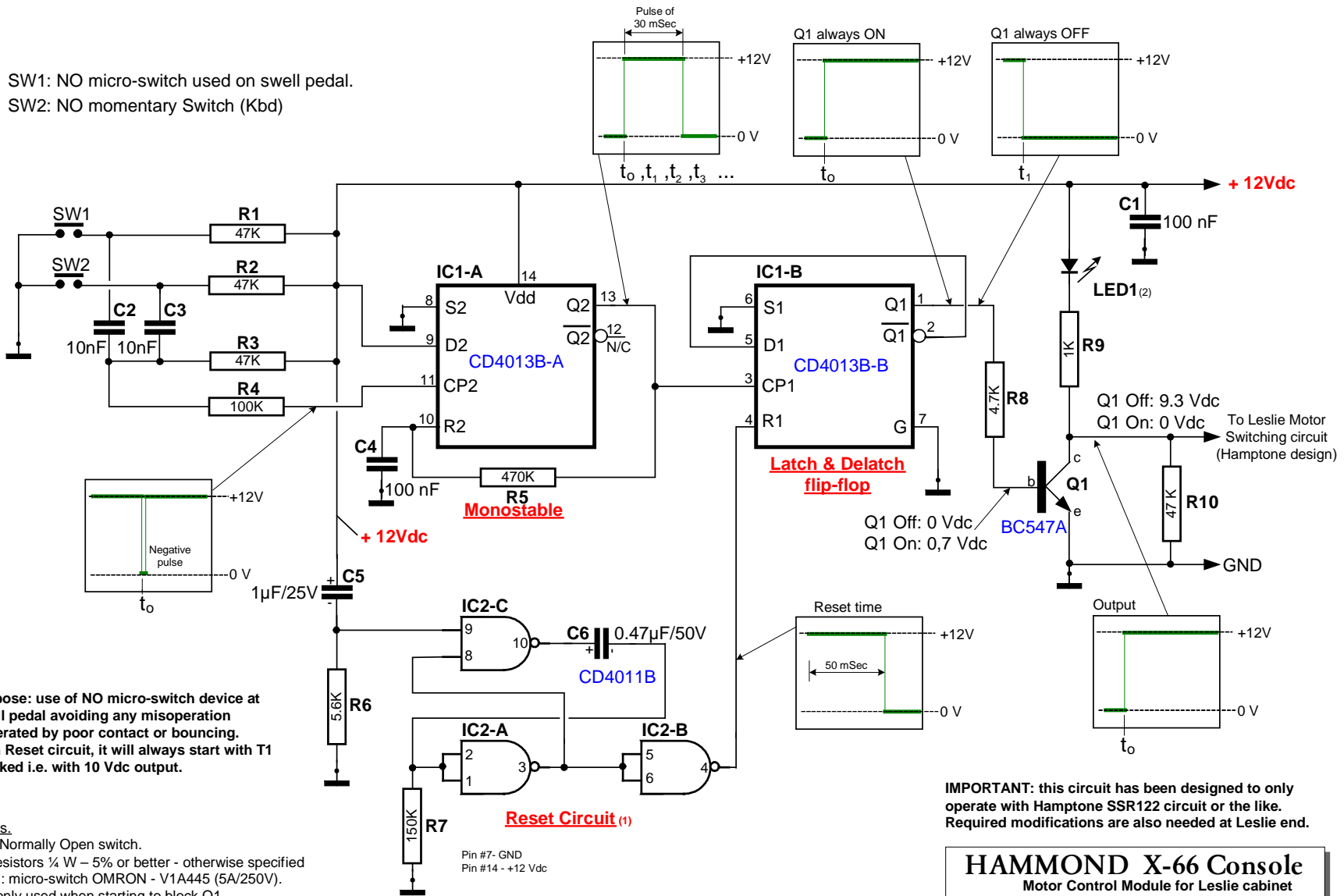

Purpose: use of NO micro-switch device at swell pedal avoiding any misoperation generated by poor contact or bouncing. With Reset circuit, it will always start with T1 blocked i.e. with 10 Vdc output.

Notes.
 NO: Normally Open switch.
 All resistors ¼ W – 5% or better - otherwise specified
 SW1: micro-switch OMRON - V1A445 (5A/250V).
 (1): only used when starting to block Q1.
 (2): optional LED indicator.
 Subject to change without advance notice.

Pin #7- GND
 Pin #14 - +12 Vdc

Hammond(R) and Leslie(R) are registered trademarks of Suzuki Musical Instrument Manufacturing Co. Ltd.

IMPORTANT: this circuit has been designed to only operate with Hamptone SSR122 circuit or the like. Required modifications are also needed at Leslie end.

HAMMOND X-66 Console
 Motor Control Module for Leslie cabinet
 File: Motor_Control_Circuit_V3.vsd
 Issued by: D.Vigin
 Date: 5/10/2008